

T-Series **Typhoon Automatic Self-Cleaning Filter**



Morrill

INDUSTRIES, INC.

IRRIGATION EQUIPMENT MANUFACTURING

New Typhoon Technology!

*The Latest Technological Breakthrough
in Automated Filtration Available!*

- **ONBOARD PROGRAMMABLE LOGIC CONTROLLER**
- **TOTALLY AUTOMATED SELF-CLEANING**
- **100% STAINLESS STEEL CONSTRUCTION**



Designed for Today's Exacting Requirements - Engineered for Tomorrow's Trouble Free Operation

**Built to Meet the Demanding Requirements of Agricultural Irrigation,
Municipal and Industrial Applications**

24754 East River Road, Escalon, CA 95320 • Phone: 209.838.2550 • Fax: 209.838.3544 • www.morrillinc.com



HOW THE TYPHOON FILTER WORKS

The Typhoon Automatic Self Cleaning Filter is an advanced, yet easy to operate Automatic Filter, with a self-cleaning mechanism driven by an electric motor. The Typhoon is designed to work with a wide range of filtration requirements from .0277" down to .0006" (705 -15 Microns).

Filtering Process:

The water enters through the filter inlet pipe and flows through the screen from the inside to outside. The "filter cake" (contaminants) accumulates on the screen surface and causes pressure differentials to develop between the Filter inlet and outlet. A pair of Pressure Transducers read the differential (usually set at 8 psi) and signals the controller to start the cleaning operation.

Self-Cleaning Process:

The Typhoon initiates the self-cleaning process when either the pressure differential across the screen reaches a per set value or the flush timer reaches its preset time interval. During the flush (Scanning) cycle the Typhoon's exhaust flush valve opens to flush the scanner. When the exhaust flush valve is open the scanner drive motor is activated and the scanner rotates in a spiral motion (rotational and linear motion) removing the contaminants from the screen. The scanner consists of a central tube with suction scanner nozzles equally spaced along the length of this tube. The exhaust flush valve connects the internal cavity of the scanner to the atmospheric pressure outside the filter body. When the exhaust flush valve is opened the differential pressure between the water inside the filter and the atmosphere outside the filter creates high suction forces at the openings of each of the suction scanner nozzles.

This suction force causes water to flow backwards through a small area of screen in front of each nozzle, pulling the contaminants off the screen and sucking it into the suction scanner nozzle and out through the exhaust valve to waste.

The drive mechanism rotates the suction scanner in a slow, controlled motion. The cleaning cycle is completed in approximately 45 seconds. During this time the nozzles cover 100% of the screen removing the contaminants from the entire screen surface. During the self-cleaning cycle, filtered water continues to flow downstream of the filter.

The exhaust valve also cleans the end cap of contaminants. This cleaning action is accomplished by the use of an adjustable nozzle plate at the entrance end of the filter screen. This nozzle plate, when properly adjusted for flow, and in conjunction with a velocity tube, creates higher velocity down the length of the filter screen causing the contaminants to be forced into the oversized end cap. Once the contaminants are in the end cap deflectors are used to keep these contaminants from turbulating back into the screen area. This approach to cleaning contaminants from the filter will greatly prolong the duration between scanning (cleaning) cycles. The total duration of the flush cycle will be 45 seconds.

Control System:

The Typhoon Automatic Self Cleaning Filter Operation and Cleaning Cycle is controlled and monitored by a Programmable Logic Control (PLC). The PLC, in conjunction with two pressure transducers and four proximity switches, will control the operation and timing of the drive motor and exhaust flush valve. It will also give operational information such as; pressure differential, standard filtering mode, flush valve mode, default mode.

The PLC allows the system maximum flexibility of operation. Included in the system is a high pressure differential pump shut down circuit and one additional open circuit (Can be normally open or normally closed) for other uses, such as an alarm or discharge valve controller. Another feature of the controller is that by entering a code into the monitor you will change from English to Spanish on all displayed information.



TYPHOON AUTOMATIC FILTERS

MODEL
T-600

Maximum Flow Rate *	600 US GPM	136 M ³ /HR
Minimum Working Pressure **	30 PSI	2 BAR
Maximum Working Pressure	150 PSI	10 BAR
Filter Area	410 IN ²	2645 CM ²
Inlet/Outlet Diameter	3" - 4" - 6"	75 - 100 - 150 mm
Filter Housing	8 5/8"	219 mm
Maximum Working Temperature	180° F	82° C
Weight	3" Flanges - 460#	75 mm Flanges - 209Kg
	4" Flanges - 470#	100 mm Flanges - 213Kg
	6" Flanges - 480#	150 mm Flanges - 218Kg

MODEL
T-800

Maximum Flow Rate *	850 US GPM	193 M ³ /HR
Minimum Working Pressure **	30 PSI	2 BAR
Maximum Working Pressure	150 PSI	10 BAR
Filter Area	570 IN ²	3677 CM ²
Inlet/Outlet Diameter	4" - 6" - 8"	100 - 150 - 200 mm
Filter Housing	10 3/4"	273 mm
Maximum Working Temperature	180° F	82° C
Weight	4" Flanges - 600#	100 mm Flanges - 272Kg
	6" Flanges - 610#	150 mm Flanges - 277Kg
	8" Flanges - 620#	200 mm Flanges - 281Kg

MODEL
T-1200

Maximum Flow Rate *	1200 US GPM	272 M ³ /HR
Minimum Working Pressure **	30 PSI	2 BAR
Maximum Working Pressure	150 PSI	10 BAR
Filter Area	834 IN ²	5381 CM ²
Inlet/Outlet Diameter	6" - 8" - 10"	150 - 200 - 250 mm
Filter Housing	12 3/4"	324 mm
Maximum Working Temperature	180° F	82° C
Weight	6" Flanges - 705#	150 mm Flanges - 320Kg
	8" Flanges - 720#	200 mm Flanges - 327Kg
	10" Flanges - 740#	250 mm Flanges - 336Kg

MODEL
T-1600

Maximum Flow Rate *	1600 US GPM	363 M ³ /HR
Minimum Working Pressure **	30 PSI	2 BAR
Maximum Working Pressure	150 PSI	10 BAR
Filter Area	1074 IN ²	6930 CM ²
Inlet/Outlet Diameter	8" - 10" - 12"	200 - 250 - 300 mm
Filter Housing	14"	355 mm
Maximum Working Temperature	180° F	82° C
Weight	8" Flanges - 815#	200 mm Flanges - 370Kg
	10" Flanges - 830#	250 mm Flanges - 377Kg
	12" Flanges - 855#	300 mm Flanges - 388Kg

*Maximum Flow Rate - Contact Manufacturer for optimum flow depending on filtering requirements and quality of water.

** Minimum Working Pressure - Pressure requirement may be lowered if pressure is increased for flushing.

**MODEL
T-2200**

Maximum Flow Rate *	2200 US GPM	500 M ³ /HR
Minimum Working Pressure **	30 PSI	2 BAR
Maximum Working Pressure	150 PSI	10 BAR
Filter Area	1498 IN ²	9665 CM ²
Inlet/Outlet Diameter	8" - 10" - 12"	200 - 250 - 300 mm
Filter Housing	16"	406 mm
Maximum Working Temperature	180° F	82° C
Weight	8" Flanges - 950#	200 mm Flanges - 431Kg
	10" Flanges - 960#	250 mm Flanges - 435Kg
	12" Flanges - 990#	300 mm Flanges - 449Kg

**MODEL
T-3000**

Maximum Flow Rate *	3150 US GPM	715 M ³ /HR
Minimum Working Pressure **	30 PSI	2 BAR
Maximum Working Pressure	150 PSI	10 BAR
Filter Area	2138 IN ²	13,794 CM ²
Inlet/Outlet Diameter	10" - 12" - 14"	250 - 300 - 350 mm
Filter Housing	20"	508 mm
Maximum Working Temperature	180° F	82° C
Weight	10" Flanges - 1230#	250 mm Flanges - 558Kg
	12" Flanges - 1260#	300 mm Flanges - 572Kg
	14" Flanges - 1290#	350 mm Flanges - 585Kg

*Maximum Flow Rate - Contact Manufacturer for optimum flow depending on filtering requirements and quality of water.

** Minimum Working Pressure - Pressure requirement may be lowered if pressure is increased for flushing.

Flushing Data:

Exhaust Flush Valve	2 1/2" (2" on T-600 and T-800)	63 mm (50 mm on T-600 and T-800)	
Flushing Cycle Time	45 seconds	45 seconds	
Waste Water Per Cycle	(T600) 70 Gallons	265 Liters	At 30 PSI - 2 BAR
Waste Water Per Cycle	(T800) 80 Gallons	303 Liters	At 30 PSI - 2 BAR
Waste Water Per Cycle	(T1200) 80 Gallons	303 Liters	At 30 PSI - 2 BAR
Waste Water Per Cycle	(T1600) 90 Gallons	341 Liters	At 30 PSI - 2 BAR
Waste Water Per Cycle	(T2200) 100 Gallons	379 Liters	At 30 PSI - 2 BAR
Waste Water Per Cycle	(T3300) 120 Gallons	455 Liters	At 30 PSI - 2 BAR
Minimum Flow For Flushing	(T600)(T800) 150 US Gallons	34 M ³ /HR	At 30 PSI - 2 BAR
Minimum Flow For Flushing	(T1200)(T1600)(T2200)(T3300) 220 US Gallons	50 M ³ /HR	At 30 PSI - 2 BAR

Control And Electricity:

3 Phase System

12 VDC System

Power Supply	220 / 380 / 460 VAC 3ø	12 VDC
Power Control Voltage (PLC)	24 VDC	24 VDC
Electric Drive Motor	1/3 HP 220 / 380 / 460 3ø 50/60 Hz	1/4 HP 12 VDC
Flush Valves Drive Motor	24 VDC	12 VDC
Current Consumption	1.5 Amps (At 460 VAC 3ø)	22 Amps (12 VDC)

Construction Materials:

Filter Housing And Lid	304 Stainless Steel (316 Stainless Steel Available)
Screens	316L Stainless Steel
Cleaning Mechanism	304 Stainless Steel (316 Stainless Steel Available)
Exhaust Valves	Butterfly with Nylon II Disk with EPDM Seat
Seal And Bearings	Permachem - Duralast - EPDM - UHMW
Control Box	304 Stainless Steel (Nema 4X)

The materials used to build every T-Series **TYPHOON FILTER** are designed to meet the toughest challenges of in-field use.

The quality construction methods, perfected through years of ongoing development, insure that your new **TYPHOON FILTER** will give you years of trouble free operation.

Typhoon Digital Control Panel

Every TYPHOON FILTER features a Digital Control Panel that will allow you to Manually Control the Filter Functions and vary the Parameters built into the PLC.

QUALITY CONSTRUCTION MATERIALS:

Filter Housing Lid	304 Stainless Steel (316 Stainless Steel Available)
Screens	316 Stainless Steel
Cleaning Mechanism	304 Stainless Steel (316 Stainless Steel Available)
Exhaust Butterfly Valve	Nylon 11 Disk Epdm Seat
Seals and Bearings	Permach-Duralast-EPDM-UHMW
Control Box	304 Stainless Steel (Nema 4x)

Stainless Steel Weave Wire Screen

Mesh	24	40	60	120	150	*200	*300	*450	*600
Mesh Opening in	.0277	.0150	.0092	.0046	.0037	.0030	.0019	.0010	.0006
Micron	705	380	233	118	95	75	48	25	15

*Indicates optimesh weave and have a absolute Micron rating. The Mesh count is for comparison only. All others are square weave and have a nominal Micron rating.



GOOD QUALITY WATER GPM (M³/HR)

SIZE	24 MESH	40 MESH	60 MESH	120 MESH	150 MESH	200 MESH	300 MESH	450 MESH	600 MESH
T-600	600 (136)	600 (136)	600 (136)	575 (131)	575 (131)	490 (111)	450 (102)	410 (93)	370 (84)
T-800	850 (193)	850 (193)	850 (193)	800 (182)	800 (182)	685 (156)	630 (143)	570 (129)	515 (117)
T-1200	1200 (273)	1200 (273)	1200 (273)	1120 (254)	1120 (254)	960 (218)	880 (200)	800 (182)	720 (164)
T-1600	1600 (363)	1600 (363)	1600 (363)	1500 (341)	1500 (341)	1410 (320)	1290 (293)	1175 (267)	1060 (241)
T-2200	2200 (500)	2200 (500)	2200 (500)	2095 (476)	2095 (476)	1800 (409)	1650 (375)	1500 (341)	1350 (307)
T-3000	3150 (715)	3150 (715)	3150 (715)	2990 (679)	2990 (679)	2565 (583)	2350 (534)	2140 (486)	1925 (437)

AVERAGE QUALITY WATER GPM (M³/HR)

SIZE	24 MESH	40 MESH	60 MESH	120 MESH	150 MESH	200 MESH	300 MESH	450 MESH	600 MESH
T-600	600 (136)	600 (136)	600 (136)	515 (117)	515 (117)	410 (93)	370 (84)	330 (75)	330 (75)
T-800	850 (193)	850 (193)	850 (193)	715 (162)	715 (162)	570 (129)	515 (117)	455 (103)	455 (103)
T-1200	1200 (273)	1200 (273)	1200 (273)	1000 (227)	1000 (227)	800 (182)	720 (164)	640 (145)	640 (145)
T-1600	1600 (363)	1600 (363)	1600 (363)	1345 (305)	1345 (305)	1075 (244)	970 (220)	860 (195)	860 (195)
T-2200	2200 (500)	2200 (500)	2200 (500)	1875 (426)	1875 (426)	1500 (341)	1350 (307)	1200 (273)	1200 (273)
T-3000	3150 (715)	3150 (715)	3150 (715)	2675 (607)	2675 (607)	2150 (488)	1925 (437)	1710 (388)	1710 (388)

POOR QUALITY WATER GPM (M³/HR)

SIZE	24 MESH	40 MESH	60 MESH	120 MESH	150 MESH	200 MESH	300 MESH	450 MESH	600 MESH
T-600	600 (136)	600 (136)	575 (131)	450 (102)	450 (102)	370 (84)	330 (75)	290 (66)	290 (66)
T-800	850 (193)	850 (193)	800 (182)	630 (143)	630 (143)	515 (117)	460 (104)	400 (91)	400 (91)
T-1200	1200 (273)	1200 (273)	1120 (254)	880 (200)	880 (200)	720 (164)	640 (145)	560 (127)	560 (127)
T-1600	1600 (363)	1600 (363)	1505 (342)	1185 (269)	1185 (269)	970 (220)	860 (195)	755 (171)	755 (171)
T-2200	2200 (500)	2200 (500)	2100 (477)	1650 (375)	1650 (375)	1350 (307)	1200 (273)	1050 (238)	1050 (238)
T-3000	3150 (715)	3150 (715)	2995 (680)	2350 (534)	2350 (534)	1925 (437)	1710 (388)	1500 (341)	1500 (341)

T-SERIES *Typhoon* FILTER

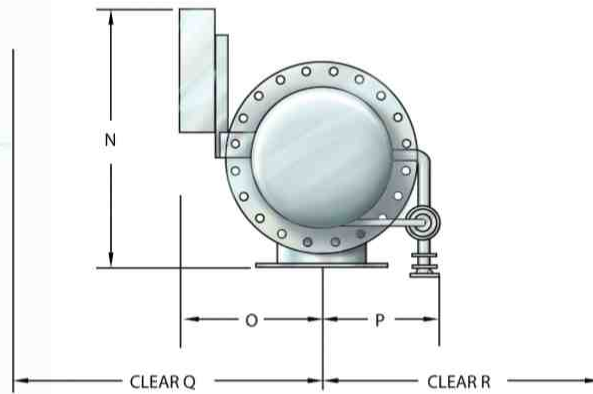
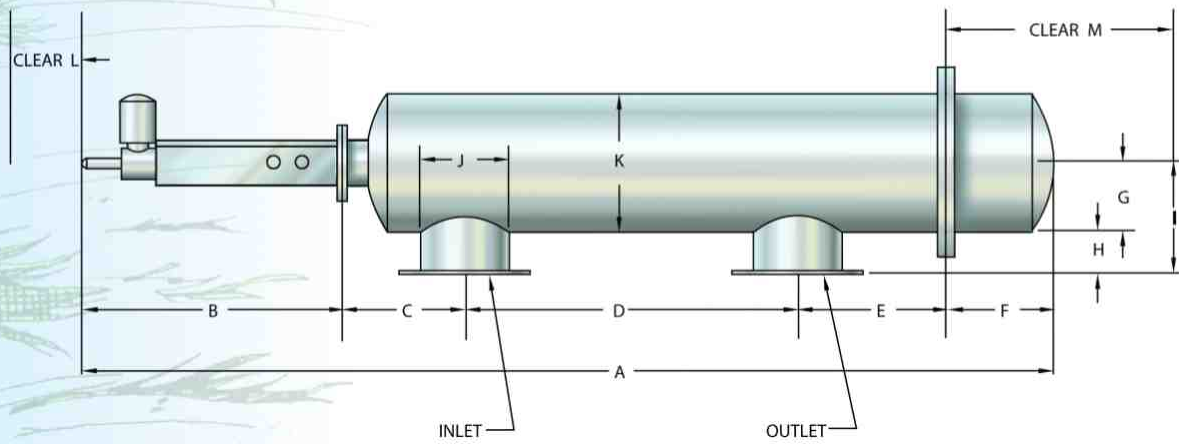

TYPHOON FILTER - MEASUREMENTS & DIMENSIONS

SIZE	A	B	C	D	E	F	G	H	I	J	K	L	M	N	O	P	Q	R
T-600-33	103.5	35	16	24	12.5	16	4.31	5.69	10	3.5	8.63	8	31	33	15	13	35	25
T-600-44	103.5	35	16	24	12.5	16	4.31	5.69	10	4.5	8.63	8	31	33	15	13	35	25
T-600-66	103.5	35	16	24	12.5	16	4.31	5.69	10	6.63	8.63	8	31	33	15	13	35	25

SIZE	A	B	C	D	E	F	G	H	I	J	K	L	M	N	O	P	Q	R
T-800-44	108	35	17	26	14	16	5.38	5.63	11	4.5	10.75	8	34	34	16	14	36	26
T-800-66	108	35	17	26	14	16	5.38	5.63	11	6.63	10.75	8	34	34	16	14	36	26
T-800-88	108	35	17	26	14	16	5.38	5.63	11	8.63	10.75	8	34	34	16	14	36	26

SIZE	A	B	C	D	E	F	G	H	I	J	K	L	M	N	O	P	Q	R
T-1200-66	112	35	18	30	13	16	6.38	5.63	12	6.63	12.75	8	36	35	17	15	37	27
T-1200-88	112	35	18	30	13	16	6.38	5.63	12	8.63	12.75	8	36	35	17	15	37	27
T-1200-1010	112	35	18	30	13	16	6.38	5.63	12	10.75	12.75	8	36	35	17	15	37	27

SIZE	A	B	C	D	E	F	G	H	I	J	K	L	M	N	O	P	Q	R
T-1600-66	121	35	18	36	16	16	7	6	13	6.63	14	8	44	36	18	16	38	28
T-1600-88	121	35	18	36	16	16	7	6	13	8.63	14	8	44	36	18	16	38	28
T-1600-1010	121	35	18	36	16	16	7	6	13	10.75	14	8	44	36	18	16	38	28

SIZE	A	B	C	D	E	F	G	H	I	J	K	L	M	N	O	P	Q	R
T-2200-88	128.5	35	19	44	14.5	16	8	6	14	8.63	16	8	50	37	19	18	39	30
T-2200-1010	128.5	35	19	44	14.5	16	8	6	14	10.75	16	8	50	37	19	18	39	30
T-2200-1212	128.5	35	19	44	14.5	16	8	6	14	12.75	16	8	50	37	19	18	39	30

SIZE	A	B	C	D	E	F	G	H	I	J	K	L	M	N	O	P	Q	R
T-3000-1010	134	35	19	48	16	16	10	6	16	10.75	20	8	55	39	21	20	41	32
T-3000-1212	134	35	19	48	16	16	10	6	16	12.75	20	8	55	39	21	20	41	32
T-3000-1414	134	35	19	48	16	16	10	6	16	14	20	8	55	39	21	20	41	32

T-Series **Typhoon Automatic Self-Cleaning Filter**

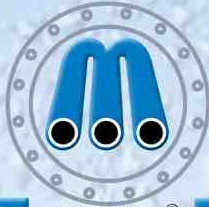
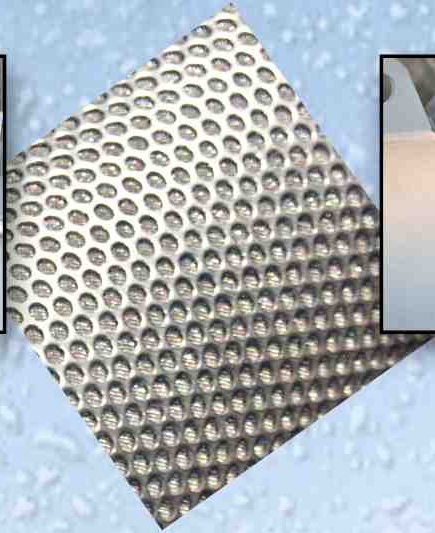

Morrill
INDUSTRIES, INC.

IRRIGATION EQUIPMENT MANUFACTURING

24754 East River Road, Escalon, CA 95320

Phone: (209) 838-2550

Fax: (209) 838-3544

www.morrillinc.com

Call today to discuss your Needs!
See Your Authorized Area Dealer:

