

Morrell
INDUSTRIES, INC.
IRRIGATION EQUIPMENT MANUFACTURING

**TWIN SPHERE
CONNECTOR WITH
THREADED UNIONS**
TZU SERIES TWIN SPHERE RUBBER
EXPANSION JOINT - UNION X UNION

Features:

- * Applicable for suction and delivery(discharge).
- * Ability to absorb large displacement due to eccentric, axial, and angular movement.
- * Excellent for absorbing thermal expansion and eliminating sound and vibration.
- * Female Threaded Unions allow for easy installation.

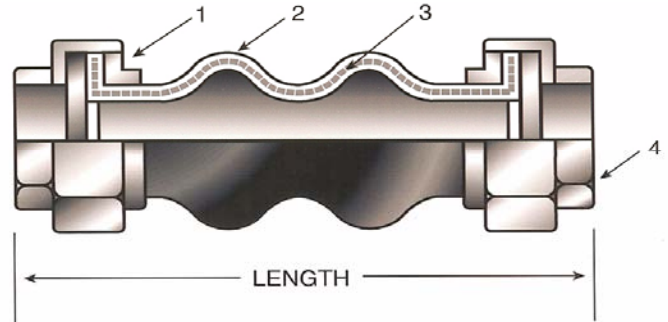

DIMENSION AND ALLOWABLE MOVEMENT

PART NUMBER	SIZE	FACE TO FACE DIMENSION	ALLOWABLE MOTION RATINGS*				INSTALLATION TOLERANCES				FLANGE THICKNESS	APPROX WEIGHT
			COMPRESSION	ELONGATION	LATERAL	ANGULAR	COMPRESSION	ELONGATION	LATERAL	ANGULAR		
EJTU-12	1 1/2"	7"	1"	3/4"	1"	30°	1/4"	1/8"	5/16"	10°	.630"	10 lbs.
EJTU-34	2"	7"	1"	3/4"	1"	30°	1/4"	1/8"	5/16"	10°	.630"	11 lbs.
EJTU-1	2 1/2"	7"	1"	3/4"	1"	30°	1/4"	1/8"	5/16"	10°	.709"	12 lbs.
EJTU-114	3"	7"	1"	3/4"	1"	30°	1/4"	1/8"	5/16"	10°	.709"	14 lbs.
EJTU-112	4"	9"	1 3/8"	1"	1 1/4"	30°	1/4"	1/8"	5/16"	10°	.709"	20 lbs.
EJTU-2	5"	9"	1 3/8"	1"	1 1/4"	30°	1/4"	1/8"	3/8"	10°	.787"	25 lbs.

Warning: Do Not elongate rubber expansion joints when installing for suction service

* Non Concurrent Ratings

OPERATING CONDITIONS

Operating Pressure	140 psi
Operating Temp	14° - 158° F
Vacuum Rating	26" Hg
Burst Pressure	750 psi

MATERIALS

PART	DESCRIPTION	MATERIAL
1	Threaded Union	Malleable Iron
2	Reinforcing cloth	Nylon Fabric
3	Elastomer	EPDM

Warning: Operating pressures listed in the above table are for up to 110° F (for Neoprene) and 125° F (for EPDM)

APPLICATIONS:

- * Vibration isolation for small pumps and circulating pumps
- * Sewage disposal purifier lines.
- * Vibration isolation for air-conditioner and piping.
- * Agricultural pump and piping system connections.

Customer
Project
Engineer
Architect:
PO#

1