

ATTENTION

THIS DOCUMENT IS VALID IF AND ONLY IF YOU PERSONALLY DOWNLOADED IT FROM WWW.BRAY.COM
 IF YOU RECEIVED THIS DOCUMENT FROM ANY OTHER SOURCE, PLEASE TAKE INTO CONSIDERATION THAT ALTERATIONS
 COULD HAVE BEEN MADE. FOR AN ORIGINAL COPY, PLEASE CONTACT BRAY VALVE AT 281-894-5454

SERIES 30
ES11A-0255
Date: JULY 1996

Valve Size	Gear Operator	A	B	C	E	F	G	J	K	L	N	P
2"	20:1	3.69	1.62	4.00	5.50	1.77	1.62	1.44	1.32	2.22	5.34	8
2½"	20:1	4.19	1.75	4.00	6.00	1.77	1.62	1.44	1.91	2.47	5.34	8
3"	20:1	4.88	1.75	4.00	6.25	1.77	1.62	1.44	2.55	2.81	5.34	8
4"	20:1	6.06	2.00	4.00	7.00	1.77	1.62	1.44	3.57	3.41	5.34	8
5"	20:1	7.06	2.12	4.00	7.50	1.77	1.62	1.44	4.63	4.03	5.34	8
6"	20:1	8.12	2.12	4.00	8.00	1.77	1.62	1.44	5.45	4.53	5.34	8
8"	30:1	10.50	2.50	4.00	9.50	2.96	2.62	1.25	7.45	5.75	7.50	8
10"	30:1	12.75	2.50	4.00	10.75	2.96	2.62	1.25	9.53	7.12	7.50	8
12"	30:1	14.88	3.00	4.00	12.25	2.96	2.62	1.25	11.47	8.12	7.50	8
14"	30:1	17.05	3.00	4.00	13.62	2.96	2.62	1.25	13.04	9.38	7.50	8
14"	50:1	17.05	3.00	6.00	13.62	2.96	3.12	1.69	13.04	9.38	11.94	12
16"	30:1	19.21	4.00	4.00	14.75	2.96	2.62	1.25	14.85	10.75	7.50	8
16"	50:1	19.21	4.00	6.00	14.75	2.96	3.12	1.69	14.85	10.75	11.94	12
18"	80:1	21.12	4.25	6.00	16.00	4.14	4.56	2.38	16.85	12.00	14.94	12
20"	80:1	23.25	5.00	6.00	17.25	4.14	4.56	2.38	18.73	13.72	14.94	12

Note: K dlm is disc chordal dimension at valve face.

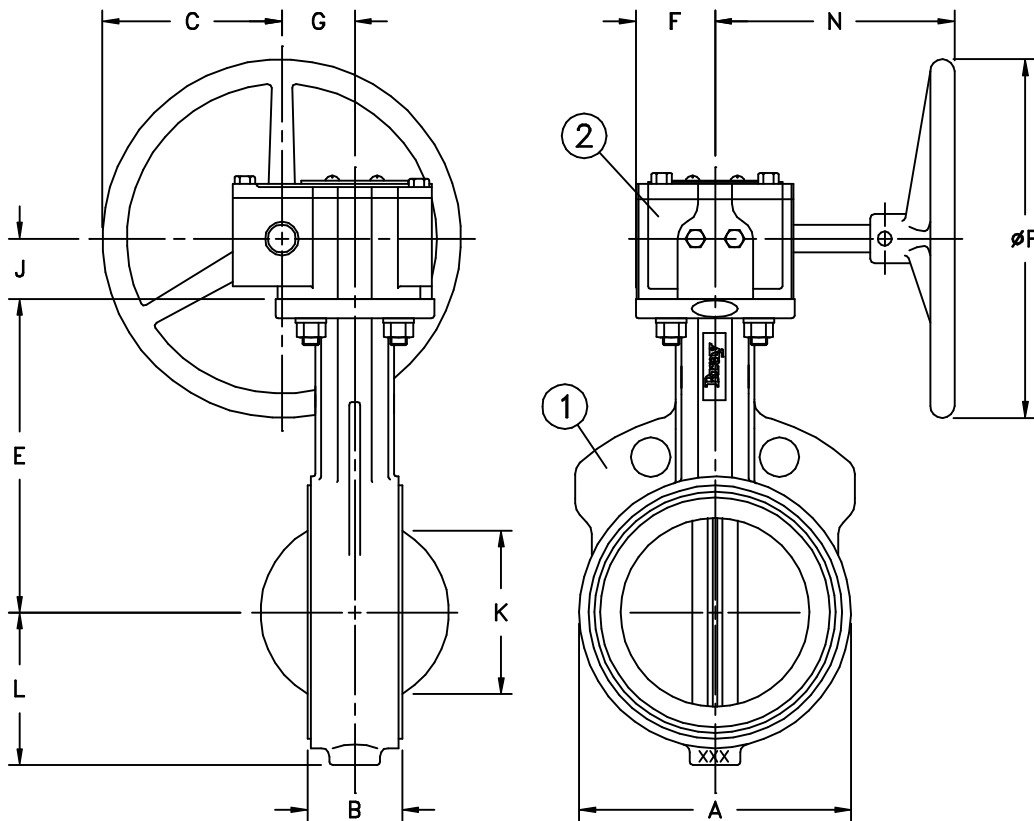

2	GEAR OPERATOR	1			
1	VALVE	1			
ITEM No.	NAME	No. REQUIRED	SERIES/PART No.	MATERIAL	SPECIFICATION/REMARKS

Valve Size _____ Flg. Drilling _____
 Pressure Rating _____
 Customer/Project _____
 Inq./P.O. No. _____
 Bray Order No. _____
 Certified Correct By _____ Date _____



BRAY VALVE & CONTROLS
 A Subsidiary of BRAY INTERNATIONAL, Inc.

DIMENSIONAL DRAWING (inches)
 SERIES 30, SIZES 2" THRU 20" BUTTERFLY VALVES
 WITH SERIES 04 GEAR OPERATORS

Series	Size	Part No.	Material Trim Code	Drawing No.
				ES11A-0255

Bray